

Dynatech[®]

Competition Exhaust Systems

INSTALLATION INSTRUCTIONS

LIT-882, REV 8



FORD F-150

STAINLESS STEEL HEADER EXHAUST SYSTEM

Note: We do our best to ensure the instructions in the box are the latest version. However in some cases where the system does not change for a new model year, inventory on the shelf may not have the latest version of the instruction manual. If you do not see your model or application listed above, please feel free to contact us at 800-848-5850 or sales@dynatechheaders.com for an updated instruction manual. We assure you the parts in the box are correct. The instructions may have added notes for a specific model year update.

'04 - '08

V-8 - 5.4 LITER ENGINES

PART NUMBERS

(4WD)

(2WD)

722-62210

722-62210

722-62220

722-62320

722-62230

722-62330

www.DynatechHeaders.com | Copyright 2017 - AFCO Performance Group

These products are intended for racing and off-road applications. Not legal for sale or use in the state of California, nor in states which have adopted California emission standards.

Congratulations on your purchase of the Dynatech / SuperMaXX system for the 2004 / 2005 Ford F150 w/5.4 liter engine. We believe, and think you will agree that this system is second to none in quality, performance, and ease of installation. Please read and understand each of the steps involved with the removal of your old system and the installation of your new header system prior to getting started. While slight variations in either the header or the vehicle may cause minor differences in the exact order of steps or the exact positions of components listed in this document, the following narrative and pictorial information should guide you during the removal and installation process to a completely satisfactory install of your new header system.

Installation Instructions

Dynatech highly recommends hiring a professional installer, one that is familiar with the installation of off-road exhaust products. Headers are designed to increase the performance of your vehicle, and as such are designed differently than your stock exhaust system. Extra care must be taken to ensure that hoses, cables, electrical lines, fuel lines, hydraulic lines, or any other objects are not in contact with, or located too close to your installed system. (Nothing should be allowed to touch or be located close to the header/exhaust system.)

Dynatech will repair or replace any products found upon our inspection to be defective in workmanship or material within 12 months from date of purchase for the original purchaser.

The Dynatech Team takes pride in providing the utmost in quality and performance. Should you have a concern about the product you receive, please contact Dynatech Customer Service at dynatechcs@dynatechheaders.com.

Dynatech is not responsible for any exhaust product that has been improperly installed, crashed, welded to, or modified in any way. Dynatech does not cover damage to any related components. Neither the seller nor Dynatech will be responsible or liable for any loss, damage, or injury resulting from the direct or indirect use of this product or inability by the purchaser to determine proper use or application of this product. Dynatech competition exhaust products are built for off-highway use only and are not intended for use on street legal, pollution controlled vehicles.

Note: These products are intended for racing and off-road applications. Not legal for sale or use in the State of California, nor in states which have adopted California emission standards.

What's in your new header kit?

Your exhaust system should contain all of the following parts. Please inventory each part prior to proceeding with the installation. **The 2WD and 4WD models are listed below where applicable.**

Parts Inventory List: These parts are common to both the 2WD and 4WD Models.

- 1 ea. Left Side (driver side) Header/Collector Assembly
- 1 ea. Right Side (passenger side) Header/Collector Assembly
- 1 ea. Donut Gasket Skin Card
 - 2 ea. 2 ½" Graphite Donut Gaskets
 - 6 ea. 10mm x 1.5 Serrated Flanged Nuts
 - 6 ea. Spacer Rings (approximately 10mm I.D.)
- 1 ea. Header Gasket / Header Bolts Skin Card
 - 2 ea. OEM Style Stainless Steel Header Gaskets
 - 16 ea. 8mm Header Bolts
 - 2 ea. Dynatech Decals

4WD Model: These parts are specific to the 4WD Model and are in addition to the parts above.

- 1 ea. Left (driver side) Catalytic Converter / X-Over Assembly
- 1 ea. Right (passenger side) Catalytic Converter
- 1 ea. "Y"-Pipe Assembly
- 2 ea. 2 ½" Stainless Steel Band Clamps
- 3 ea. O2 Extension Cables
- 5 ea. Fir Tree Cable Ties

Note: The picture shown is of the 4WD model.



2WD Model: These parts are specific to the 2WD Model and are in addition to the parts above

- 1 ea. Left (driver side) Catalytic Converter
- 1 ea. Right (passenger side) Catalytic Converter
- 1 ea. Cross-Over Tube
- 1 ea. "Y"-Pipe Assembly
- 3 ea. 2 ½" Stainless Steel Band Clamps
- 3 ea. O2 Extension Cables
- 5 ea. Fir Tree Cable Ties

Safety Notes:

While this installation can be done on the floor with the use of jack stands we strongly recommend that this job be completed utilizing a hydraulic lift or have the system installed by a professional mechanic. You will need 24 to 30 inches of ground clearance to slip the header into position from the bottom of the vehicle.

For your safety, please allow the engine to cool for a minimum of 90 minutes before starting the removal/installation steps.

The use of safety goggles is strongly recommended, as debris may be dislodged from beneath your vehicle while removing or installing parts.

While not required, the use of cotton gloves is recommended to protect not only your hands from sharp objects under the hood and chassis of your vehicle but also keeps the oils and grease off the header's stainless steel surface possibly preventing permanent stains on the headers.

Required and Optional Tools:

Miscellaneous hand tools are required for proper installation of these headers. We have listed a few of the required and optional tools to help with your installation.

- 7/8" open end wrench or O2 Sensor Socket.
- Lug wrench for removing the front wheels and tires.
- Assorted metric sockets and wrenches (5mm – 16mm)
- Ratchets, extensions, and universal joints
- Ratchet Box End Wrench (10mm) will make your installation easier. (optional)
- Torque wrench
- Rubber Mallet or Dead Blow Hammer
- Floor jack and safety stands or a hydraulic lift
- Safety glasses or goggles
- Small bottle of Anti-seize
- Penetrating Fluid (optional)
- Cotton Gloves (optional)
- Fender pads (optional)

Before You Get Started:

- Take inventory of all the parts in your new system. Make sure each piece is accounted for prior to taking your vehicle out of service.
- Look at the tool and supply list to make sure you have all the needed tools and supplies before you don't have an operating vehicle to run to the store in.

Stock System Removal: (2004 / 05 Ford F150 w/5.4 Liter engine)

(Special emphasis items will be listed in either **bold print** or **red print**)

Be sure to store/label all of the bolts, fasteners, and hardware so that they can be found and replaced if necessary during the installation of your new header system.

Differences between the removal or installation of the 2WD and 4WD will be noted in the instructions.

Under the Hood:

- Begin the removal process by removing the negative battery terminal. **Always disconnect the Negative terminal first and the Positive terminal last. When reinstalling – reverse this procedure – Positive first and Negative last.**



- Remove the oil dip-stick.
- Next loosen and remove the bolt holding the oil dip-stick tube to the left (driver side) cylinder head.
- Remove the dip-stick tube from the block.

Use precautions to insure no dirt or debris gets into the open hole to the oil pan.

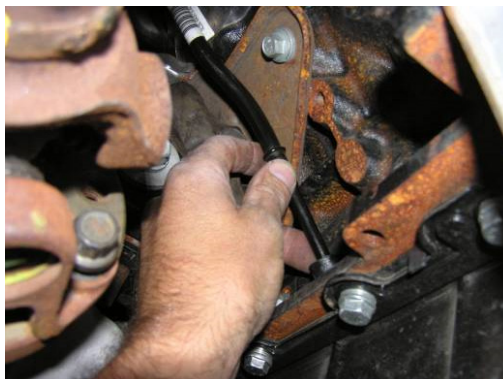
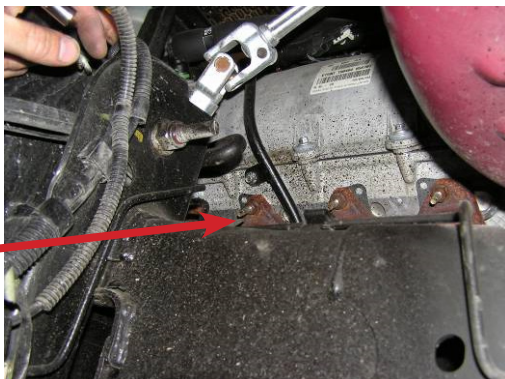
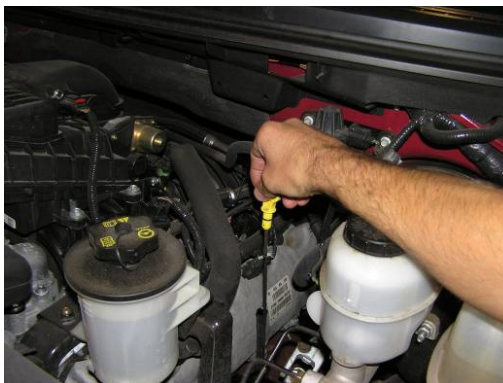

Under the Vehicle

The use of penetrating oil is recommended to aid in the removal of stubborn bolts and nuts. Do not use penetrating oil on any of the sensors throughout the system particularly the O2 sensors.

- Raise the vehicle off the ground using a floor jack and jack stands or use a hydraulic lift. (We strongly recommend the use of a hydraulic lift)
- Remove the front wheels and tires from both the left and right sides of the vehicle.
- Remove the plastic/rubber inner fender liners.
 - Loosen and remove the small screws and push lock fasteners holding the fender liners in place.
 - Remove the line clamps and holders by pushing them through the liner toward the inside of the engine bay.
 - Remove the fender/bumper support brackets on the left and right sides of the vehicle.



- Remove the front skid plate if installed to expose the underside of the engine bay. **Normally this not included with the 2WD model.**



Note: O2 sensors are delicate electronic components and should be handled very carefully. Take extra care in not contaminating the sensing end with shop towel lint, finger prints, oil, etc.

- Disconnect the front and rear LH and the rear RH oxygen sensors. These connectors are easily visible and accessible. The RH front connector is a little more difficult to get to, but not impossible. It is located on top of the transmission housing just to the rear of the transmission fill tube/dipstick.



Note: O2 sensors are delicate electronic components and should be handled very carefully. Take extra care in not contaminating the sensing end with shop towel lint, finger prints, oil, etc.

- Remove each of the four O2 sensors. Make sure that as each sensor is removed that each is marked with its relative location in the system. Store them in a clean place for re-installation during a later step.



- Continue the removal of the stock system by removing the transfer case skid plate. **This applies to the 4WD version of the F150 only.**



- Next, loosen the nuts on the clamp between the stock “Y”-pipe and the inlet tube coming forward from the muffler (do not remove the clamp from the vehicle). From there, loosen the clamp on the cross-over tube. Then remove the two bolts holding the cross-over support bracket to the transmission cross member.

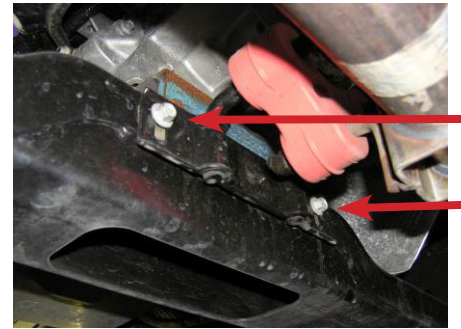

- While the new system does not require the removal of the transmission, the stock system cannot be removed intact without removing the cross-member. **The stock system may be cut out with a saws-all but we strongly suggest that the cross-member be taken out so that the stock system can be removed and saved as a complete system.**

Loosen and remove the fastener holding transmission mount to the cross-member.
Remove the bolts that hold the rear of the heat shields to the cross-member.

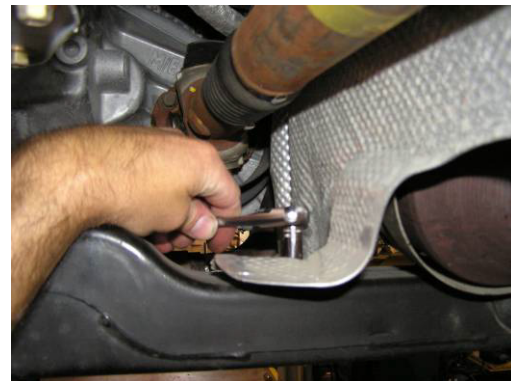

- With the above steps completed, use a stand to support the rear of the transmission while the cross-member is removed. **The transfer case of the 4WD model is shown and will not be present in the case of the 2WD model.**



- Now that the transmission is properly supported, loosen and remove the four (4) bolts that hold the cross-member to the frame.
- With the bolts removed, lower the cross-member out of the vehicle and store it for re-installation during a later step.



- Now that the cross-member has been removed, loosen but do not remove the nuts (2 on each side) on both the left and right side down tubes where the exhaust system is attached to the stock cast manifolds. The picture below shows the driveshaft of the 4WD model which may or may not be in your vehicle.



- With down tube nuts loosened, separate the left (driver side) converter and tube assembly from the right (passenger side) converter and "Y"-pipe assembly. Finish removing the down tube nuts from the left (driver) side and lower the assembly down and out from under the vehicle.
- Finish removing the down tube nuts from the right (passenger) side and slide the clamp at the rear of the "Y"-pipe back onto the inlet tube to the muffler and lower the converter/"Y"-pipe assembly down and out from under the vehicle.

- With the stock system (less the cast manifolds) removed, retrieve the transmission cross-member. Install the cross-member reversing the steps used to remove it. Tighten the four (4) bolts and nuts, then reinstall the fastener on the transmission mount and tighten.
- Recheck all the fasteners and finally remove the previously installed support under the transmission. **(Do not re-install the heat shield bolts at this time. They will be re-installed after the new system is installed.)**
- Remove the stock cast manifolds by beginning on the left (driver) side. Loosen and remove all the nuts from the studs and slide the manifold off the studs and lower the manifold out of the engine bay from beneath the vehicle. These nuts and studs should be accessible either from below or through the wheel well.



- Remove the factory gasket. Then loosen and remove all of the cast manifold studs from the left (driver) side of the engine. The studs and nuts will not be re-used, header bolts are supplied with the new system.
- Start the removal of the stock cast manifold on the right (passenger) side by removing the starter.
 - Remove the red protective cap from the starter wiring terminals and disconnect the wiring from the starter.

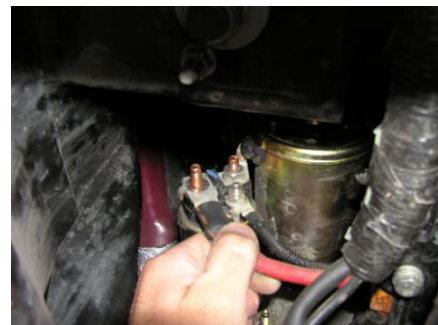
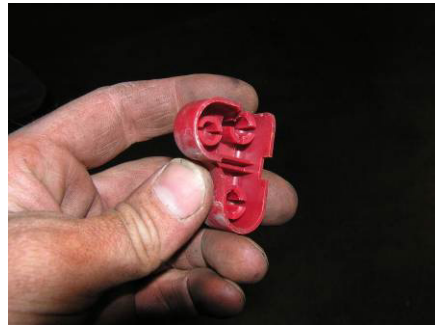

- After disconnecting the wiring, remove the starter. The cast manifold and the new header will go in and out without removing the starter, but it has to be removed to gain access to the bolts and studs on the underside of the right hand header/manifold.



- With the starter removed, loosen and remove the bolts and studs on the bottom of the cast manifold on the right (passenger) side of the engine. (Because of the engine offset to the right in the engine bay, the cast manifold will not come out unless all of the studs are removed from the lower side of the cast manifold.)
- Remove the nuts from the top side of the right manifold. Also remove any of the studs you can reach at this time. Wiggle the manifold out and over the remaining studs and lower it out of the engine bay.
- Remove the factory gasket and the remaining balance of the studs.



- This completes the stock system removal procedures. Make sure to gather all of the parts, nuts, and bolts so that they can be reinstalled if necessary during the installation of your new system.
- If necessary clean the head surfaces in preparation for installing your new headers/gaskets.
- Proceed to the “**Installing Your New System**” section.

Installing your new SuperMaxx Header System

Before installing the headers: If you have a manual transmission you must install the clutch line clamp as indicated below.

- Your new header system comes with OEM style gaskets and replacement header bolts. Begin the installation of your new system by preparing the eight (8) bolts for the left side header. Use a good brand of anti-seize and apply a small amount to the thread surface.
- Place one of the OEM style gaskets on the head surface and start two of the prepared bolts through the outside lower holes of the gasket. Turn the two (2) bolts in two of three turns to prevent cross-threading. **(Make sure that the single rivet is on the upper side of the gasket and corresponds to the "U" shape on the outside profile of the header flange.)** Notice that the end holes on the header are slotted to slip over these bolts.



- Insert the header up from the bottom of the engine bay, and hang the header on the two outside lower bolts. Notice the front drive shaft in the picture above. This may or may not be present on your vehicle depending model.



- Install the remainder of the prepared bolts in the left (driver) side. **Be sure to screw them in by hand several turns to guard against cross-threading.**
- Use the torque chart below to tighten the bolts against the header flange.

Use this torque chart for both the left and right header flanges. Torque each bolt to approximately 20 ft/lbs.

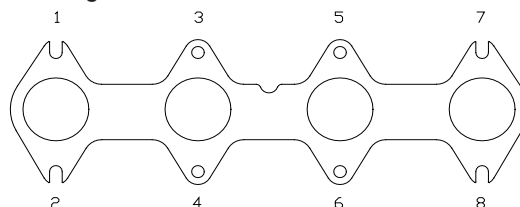

- As in the bolt preparation step above, prepare the eight (8) bolts for the right (passenger) side header with anti-seize.
- Place one of the OEM style gaskets on the head surface and start two of the prepared bolts through the outside lower holes of the gasket. Turn the two (2) bolts in two of three turns to prevent cross-threading. **(Make sure that the single rivet is on the upper side of the gasket and corresponds to the “U” shape on the outside profile of the header flange.)** Notice that the end holes on the header are slotted to slip over these bolts.



- Insert the header up from the bottom of the engine bay, and hang the header on the two outside lower bolts.
- Install the remainder of the prepared bolts in the left (driver) side. **Be sure to screw them in by hand several turns to guard against cross-threading.**
- Use the torque chart above to tighten the bolts against the header flange.
- Locate two of the O2 sensor extension cables. Use these extensions to plug into the front and rear O2 sensor connectors on the left (driver) side in the vehicle wiring harness.

Note: The “keeper clip” on the round portion of the cable extension where it plugs into the mating part in the wiring harness serves to locate/index the wiring to the O2 sensor. The small tabs placed around the outside of the connector barrel may or may not need to be ground or cut off. The OEM manufacturer may use a slightly different connector as far as these additional keys are concerned but have no bearing on how the connectors go together because of the “keeper clip”.

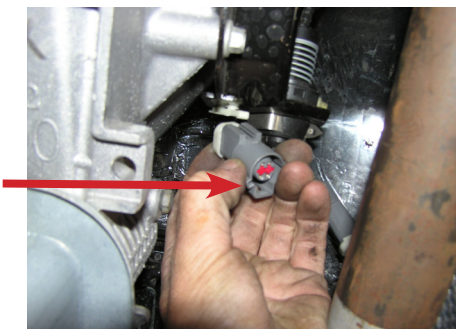

Notice the connectors with the external tabs removed to allow for plug in.

- Locate the third and final O2 extension cable, remove any tabs necessary, and plug it into the rear O2 wiring harness connector on the right (passenger) side.
- Route this cable up and over the top of the right side heat shield toward the rear end of the shield.

- Open the donut gasket skin-card and remove the contents. Slip one each donut gasket over the ends of both the left and right side collectors. Likewise place one of the spacer rings over each of the three studs on each collector.



- In the same manner as with the header bolts, place a small dab of anti-seize on each of the collector studs on each side of the vehicle.



The following instructions apply to the 4WD model only.

- Begin with the left (driver) side catalytic converter and cross-over pipe assembly. Slide it up into the heat shield tunnel from the rear side of the transmission cross-member.



- Engage the ball socket on the end of the converter and the donut gasket on the header collector. Install a serrated flanged nut on each stud. Snug the nuts up but do not tighten at this time.
- Retrieve the right (passenger) side converter and slide it up into the heat shield tunnel from the rear side of the transmission cross-member. Engage the ball socket of the converter with the donut gasket on the right side header collector. (See the arrow in the picture below showing the converter orientation in the tunnel. You'll note that it is near vertical). As with the step above install and snug-up a serrated flanged nut on each stud. Do not fully tighten.
- Pull the "Y"-pipe out of the package. Insert the cross-over tube coming from the left (driver) side of the vehicle into the short leg of the "Y"-pipe, then insert the long leg of the "Y"-pipe into the outlet end of the right (passenger) side converter. Align the "Y"-pipe outlet with the inlet tube from the muffler (note: it may be necessary to cut off a small amount of the y-pipe outlet to properly align with the muffler inlet tube). Then slide the clamp forward to engage half of the outlet tube and half of the muffler inlet tube. (see pictures to right)

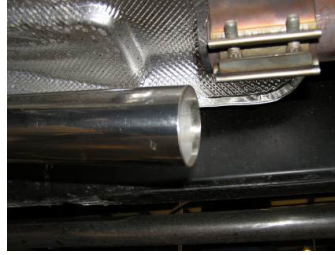

The following instructions apply to the 2WD model only.

See the supplement at the END of this document to properly identify the catalytic converters – left and right (fig. 1)

- Begin with the left (driver) side catalytic converter. Slide it up into the heat shield tunnel from the rear side of the transmission cross-member.
- Engage the ball socket on the end of the converter and the donut gasket on the header collector. Install a serrated flanged nut on each stud. Snug the nuts up but do not tighten at this time. The orientation should align the O2 sensor bung with the hole in the heat shield above it. (See the pictures below).
- Retrieve the right (passenger) side converter and slide it up into the heat shield tunnel from the rear side of the transmission cross-member. Engage the ball socket of the converter with the donut gasket on the right side header collector. As with the step above install and snug-up a serrated flanged nut on each stud. Do not fully tighten.
- Pull the “Y”-pipe out of the package. Insert the long leg of the “Y”-pipe into the outlet end of the right (passenger) side converter then insert the cross-over tube into the short leg of the “Y”-pipe, and finally insert the 90 deg bend into the back of the left side catalytic converter. Align the “Y”-pipe outlet with the inlet tube from the muffler (note: it may be necessary to cut off a small amount of the y-pipe outlet to properly align with the muffler inlet tube). Then slide the clamp forward to engage half of the outlet tube and half of the muffler inlet tube. (See pictures below).



The following instructions apply to both the 2WD and 4WD models.

- Now that the your system is in your vehicle, begin the aligning and tightening process by installing (Do not fully tighten at this time) the stainless band clamps at the junction of the cross-over pipe and the “Y”-pipe as well as the junction of the right (passenger) side catalytic converter and the “Y”-pipe. In the case of the 2WD system, the third clamp goes on the joint between the left catalytic converter on the 90 degree bend of the cross-over tube. (Note that the stainless band clamps have a step in them that must be oriented correctly for the joint to seal properly.)
- The bottom of the cross-over tube should be parallel to the bottom of the transmission cross-member and slightly higher in the vehicle. With the tube in position, (You may have to loosen or tighten the serrated nuts at the converter to allow for movement or holding as necessary – in addition you may want to hold the parts in position with a small block of wood between the converter and the cross-member) tighten the three serrated nuts on the left (driver) side converter down tight against the spacers. Remove the wooden blocks if used.
- Next rotate the right (passenger) side converter so that the O2 sensor bung is aligned with the opening in the heat shield above it. Tighten the three serrated nuts down tight against the spacers.
- Rotate the two (2) stainless steel band clamps on the “Y”-pipe to orient the bolts so they will not create either ground clearance issues or frame clearance problems and fully tight both of them. (Note: The band clamps are designed to stretch around the tube to create a seal. This means that they must be fully tightened to properly work).
- Orient the OEM clamp at the rear of the “Y”-pipe to avoid the clearance issues listed above and fully tighten.

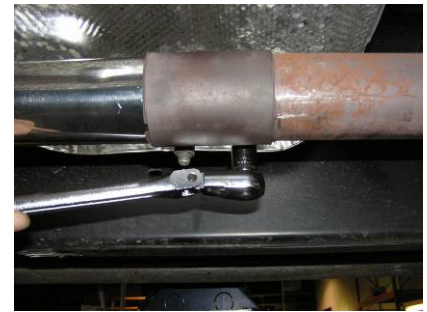
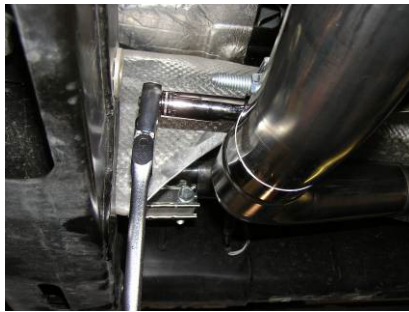

Note: O2 sensors are delicate electronic components and should be handled very carefully. Take extra care in not contaminating the sensing end with shop towel lint, finger prints, oil, etc.

- Prepare each O2 sensor for re-installation by putting a small amount of sensor safe anti-seize on the threads only. Anti-seize or non-sensor safe silicon will destroy the sensor, so use caution not to get the anti-seize on the sensor tip.
- Replace each of the O2 sensors in the system by referencing the marks made on them as they were removed from the stock system. They need to be in the same relative position as stock i.e. left front, left rear, right front, and right rear, etc. Use a 7/8” wrench or O2 sensor socket to tighten each sensor. The heat shields above the front sensors may have to be deformed to reach the sensor for tightening. Ford has used several different heat shield configurations over the year models referenced here. It may be necessary to reform the heat shields after tightening the sensors and clamps to provide adequate clearance between the sensors and or tubes and the heat shields.



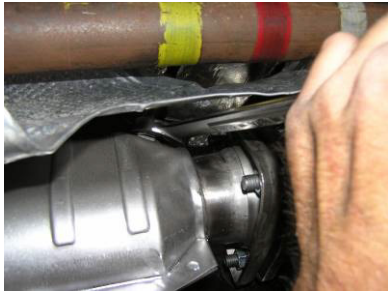

- With all of the sensors installed and tightened, connect the sensor connectors into the appropriate extension cable or wiring harness connector as is the case with the right (passenger) side front sensor. (Note: The external tabs on the O2 sensor cables may have to be removed to plug in correctly. See the notes on page 14 of this manual for further information.)

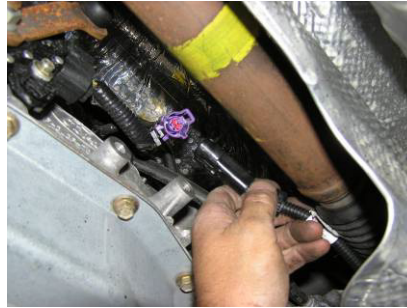
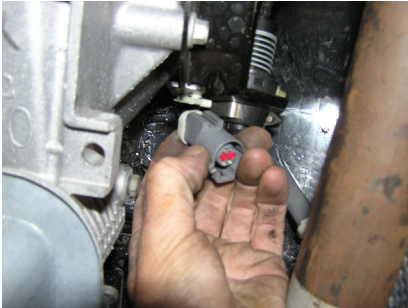

- Make sure that all the cables and sensor leads are away from heat sources or points of mechanical contact that could cut the wires.
- In the case of the right (passenger) side rear sensor and extension, use an awl, drill, or paper punch etc. to make a ¼" hole in the aluminum shield material slightly forward and above the O2 sensor. Insert the "christmas tree barbed" tie wrap into the hole and use the tie wrap to secure the connection to the outside of the heat shield.
- Re-install the two (2) bolts holding the heat shield to the transmission cross-member.



- With all the sensors properly connected and secured, it's time to re-install the starter.
 - Install the starter with the three (3) OEM bolts.
 - Install the wiring onto the appropriate terminals and tighten securely.
 - Install the small red protective cap back on the terminal ends.

- Next move to the left (driver) side to install the oil dipstick tube. Place a small amount of motor oil on the O-ring at the end of the tube and slip the end of the tube into the block.
- Insert the bolt through the dipstick tube bracket and into the bolt hole in the head and tighten securely.
- Re-insert the oil dipstick.



- Re-install the transfer case skid plate. **4WD only.**
- Re-install the engine bay skid plate. **4WD only.**



- Reverse the removal procedures to re-install the inner fender liners and the bumper/fender braces. Make sure to re-insert the line and wire harness clamps into their respective holes in the fender liners from inside the engine bay.
- Install the wheels and tires. Make sure to securely tighten the lug nuts.
- Lower the vehicle to the ground and reconnect the battery.
 - **Always disconnect the Negative terminal first and the Positive terminal last.**
 - **When reinstalling – reverse this procedure – Positive first and Negative last.**
- Check all work for completeness, bolts tightened, connectors connected, lines replaced and clamped etc. Check that no wires or lines are close to the headers where heat damage could occur or near moving parts where they could be pinched or cut. Check for misplaced tools and rags and check for oil leaks etc.

Final Checks:

- **Caution: Once again, verify that all hoses, cables, electrical lines, fuel lines, hydraulic lines, or any other objects are not in contact with, or located too closely to your installed system. (Nothing should be allowed to touch or be located close to the header/exhaust system.)**
- Start the engine. Observe the “Check Engine Light”.
- Note: In some instances you may experience a check engine light after the installation of an aftermarket exhaust system. If this occurs please contact Dynatech at 1-800-848-5850 and ask for customer service or e-mail dynatechcs@dynatechheaders.com.
- Listen for any exhaust leak “ticking” sounds. Check around each clamp and gasketed joint for leaks. If any are found, check to see that the gasket is properly installed and the joint or clamp is tightened properly.

All bolts and connections should be retightened as necessary after the system has gone through several thermal cycles and as needed thereafter.

Congratulations! That wasn't so bad, and now you have the highest quality, best performing exhaust system available installed on your vehicle.

We make every effort to build our products to the highest standards of workmanship and materials possible. This also applies to our documentation. We have tried to make the removal of the stock system and the installation of the new system as clear and concise as possible. If, however, you find points in our instruction manual that you feel need to be clarified or changed, please e-mail us your constructive comments at dynatechcs@dynatechheaders.com. We will use them to correct and enhance our documentation to the benefit of all customers.

2WD MODEL CATALYTIC CONVERTER IDENTIFICATION DIAGRAM (122-622101S)

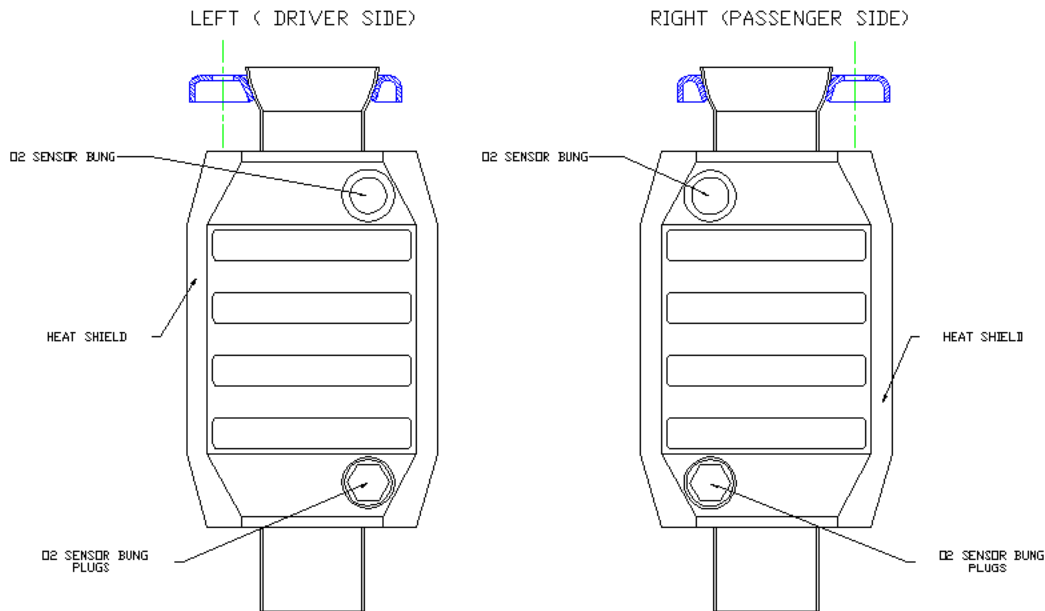

122-622101S
LEFT AND RIGHT
CATALYTIC CONVERTERS

fig. 1

Notice the position of the O2 Sensor bungs. The relationship between them, the heat shields, and inlets determine the correct position of the catalytic converters. The converters can be physically installed on the wrong side but the O2 sensor position will be incorrect and may not operate correctly if the wiring is damaged through incorrect installation.

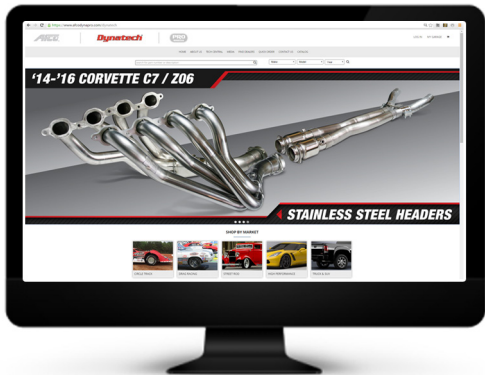

For more Dynatech products visit us on our website!

Dynatech continues to be the exhaust leader in all forms of racing and high performance applications. Advances in engineering, design and performance keep Dynatech products at the forefront of innovation, quality and performance. For 100% satisfaction, find us online at DynatechHeaders.com.



Follow us on Facebook!

For the latest in product development information, install videos, technical manuals, technical tips and event schedules, find us online at [Facebook.com/DynatechHeaders](https://www.facebook.com/DynatechHeaders).

Dynatech[®]
Competition Exhaust Systems

Dynatech Competition Exhaust Systems
P.O. Box 548, Boonville, IN 47601
(800)-848-5850

www.DynatechHeaders.com | Copyright 2017 - AFCO Performance Group

These products are intended for racing and off-road applications. Not legal for sale or use in the state of California, nor in states which have adopted California emission standards.